

## KLP® Hybrid Plastic Switch & Crossing Sleeper



- 50 Year Expected Design Life
- Low Life Cycle Costs
- Sustainable Product
- Recycled & Recyclable Materials
- Excellent Damping & High Strength Properties
- High Chemical Resistance
- Easy to install

*Sustainable plastic railway solutions*

# Lankhorst | *Mouldings*

A trade name of Lankhorst Engineered Products bv

## KLP® Hybrid Plastic Sleepers

In 2004 Lankhorst Engineered Products started with the development of the KLP® Hybrid Plastic Sleepers. The ban on creosote and the restricted availability of hardwood were the main drivers for Lankhorst to develop a plastic sleeper which is manufactured out of 100% recycled plastics as a sustainable and maintenance free alternative to timber sleepers.

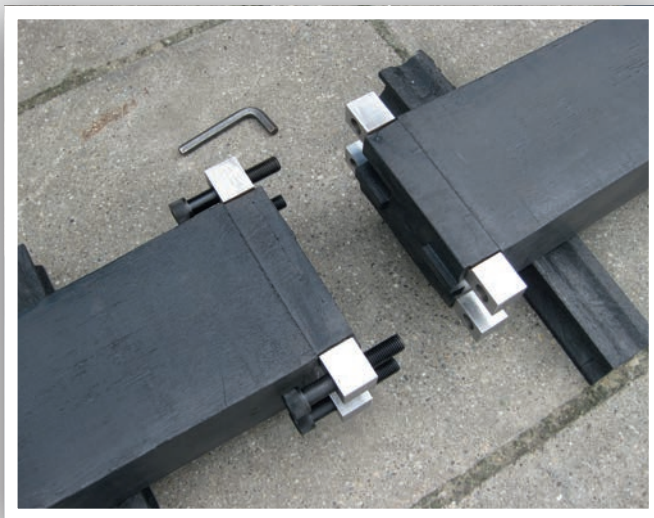

The hybrid plastic sleepers have been designed for longevity, not only to reduce the Total Cost of Ownership, but also to maintain continuous track stiffness when used for interspersing with timber sleepers. The KLP® Hybrid Plastic Sleepers are ideal for selective replacement of timber sleepers as well as for use in areas where timber or concrete sleepers are not the most beneficial choice for your track.

In 2006 the first sleepers were installed in track, followed by many installations more ever since. KLP® Hybrid Plastic Sleepers offer you good damping properties as well as optimum stiffness, due to the ductility of the plastic in combination with the strength of the steel. The sleepers keep these properties during its long expected lifespan of over 50 years.

# KLP® Hybrid Plastic Switch & Crossing Sleeper

## Field of application and sleeper types

### KLP® Hybrid Plastic Sleeper

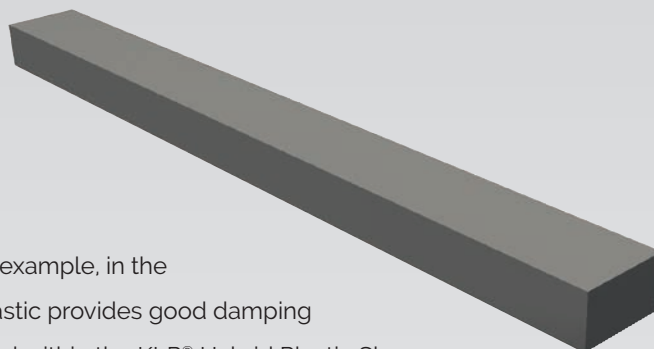
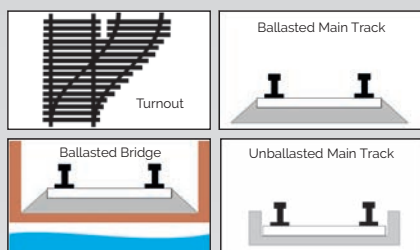

KLP® Hybrid Plastic Sleepers are ideal for ballasted track, for example, in the application of switches and crossings. The elasticity of the plastic provides good damping and reduces wear. The steel bars, that are completely encased within the KLP® Hybrid Plastic Sleeper, reinforce the sleeper and also optimize its stiffness.

### KLP® Hybrid Plastic Sleeper Connectable

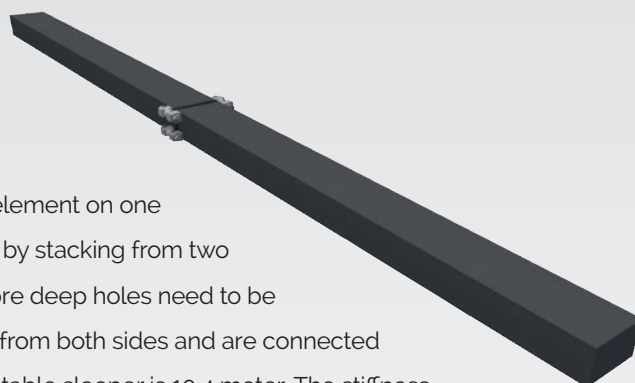
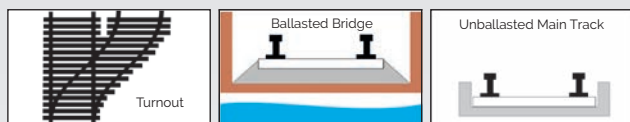

This sleeper has been equipped with the feature of a connection element on one side of the sleeper. This simplifies the installation of a long sleeper by stacking from two sides, for example, on locations with limited working space. No more deep holes need to be dug when installing long sleeper members. Sleepers are installed from both sides and are connected after installation. The maximum length obtainable with this connectable sleeper is 10,4 meter. The stiffness remains constant over the whole length of the mounted sleeper, due to its unique design.

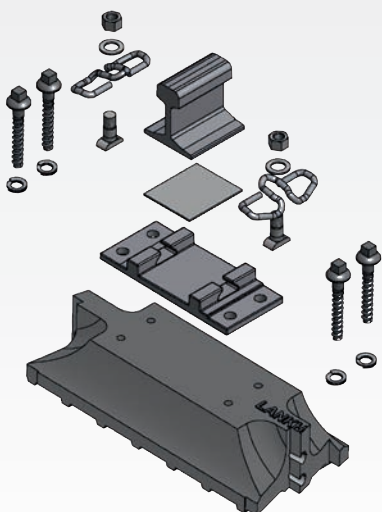

## Dimensions, specifications, certificates

Feel free to contact us with your specific request with regard to dimensions, specifications and available certificates in your region. We will gladly assist you with your local type approval process..

## KLP® Pre-drilling and Mounting Service

Lankhorst offers you a pre-drilling and mounting service for a faster installation on location. Whether you want pre-drilled sleepers on one or two sides or even if you require pre-mounting of baseplates.

## History of Royal Lankhorst Euronete

### How it began...

1803 - Nicolaas Jurjan Lankhorst started a rope manufacturing factory in Sneek, The Netherlands. At that time ropes and yarns were made of natural fibers like sisal, hemp, jute and coco yarn.

1964 - A revolution took off in rope and yarn production. Plastics were introduced and by that new yarn and rope types, with a more consistent quality and longer lifetime. The waste materials of the plastic yarn production proved to be useful for a second life.



1975 - Lankhorst started to produce the first plastic molded products.

1986 - Lankhorst Recycling was born. The plastic product program was extended ever since.

1998 - The Portuguese Grupo Euronete and the Lankhorst Group merged into one new Lankhorst Euronete Group.

2003 - Queen Beatrix of the Kingdom of the Netherlands granted the predicate "Royal" to the company

2004 - KLP® Hybrid Plastic Sleepers were developed

2006 - First KLP® Hybrid Plastic Sleeper in track in The Netherlands

### Today ...

Since Lankhorst produced its first plastic post through the process of intrusion in the '70s, many innovations have come to maturity. Today Lankhorst has their own Research and Development department capable of designing, calculating and testing products. Lankhorst now serves a variety of markets with large plastic products molded from either recycled plastics or new materials.

## Service and Partners

For more information and advise, please consult our website [www.lankhorstrail.com/en](http://www.lankhorstrail.com/en)



Official Service Partner:



Prinsengracht 2  
P.O. Box 203  
8600 AE Sneek - The Netherlands

T +31 (0)515-487539  
I [www.lankhorstrail.com/en](http://www.lankhorstrail.com/en)  
E [info@lankhorstrail.com](mailto:info@lankhorstrail.com)

